

Artemis Labs LA-1

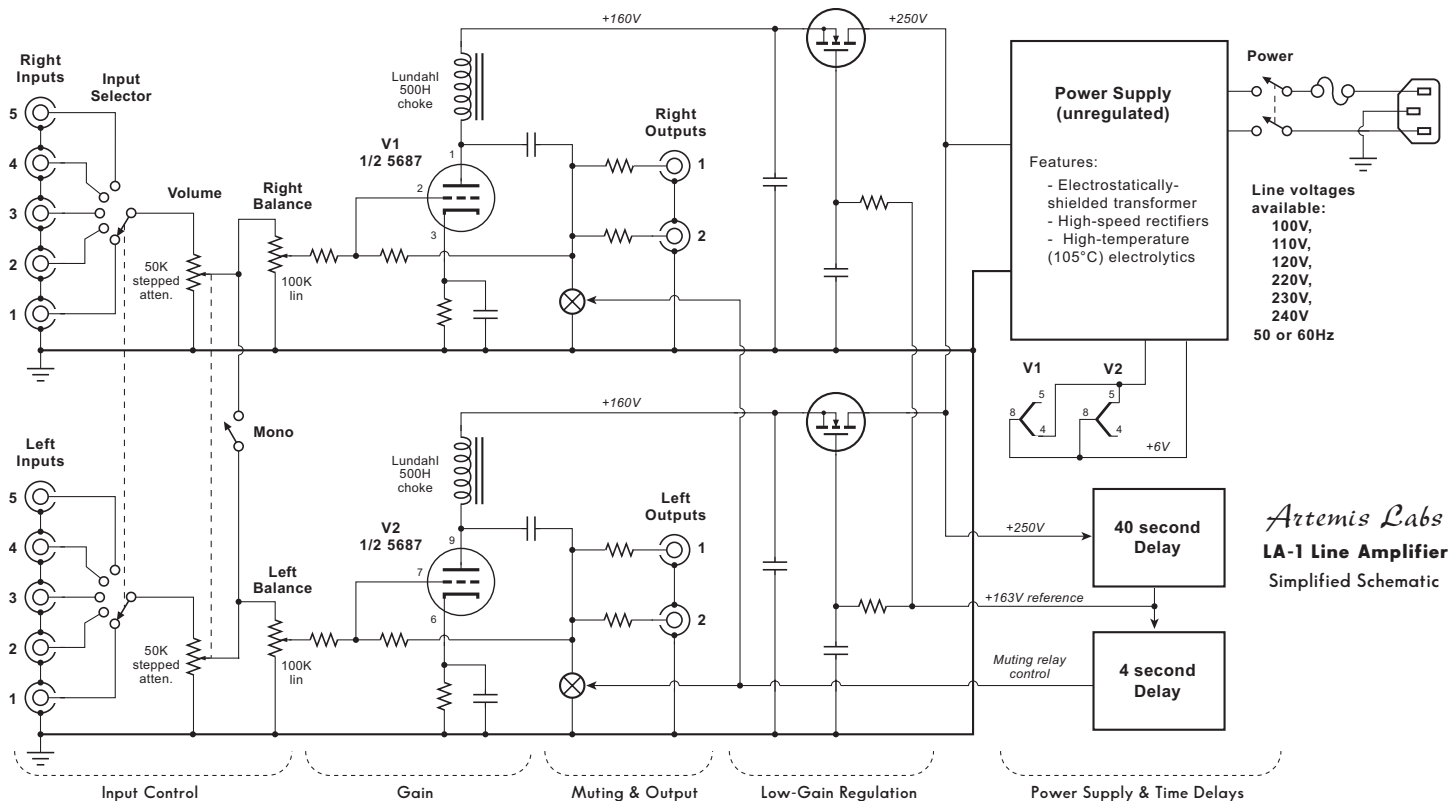

Artemis Labs
LA-1 Line Amplifier
Simplified Schematic

Single-triode gain stage with choke loading

Experience has shown that the best audio quality is achieved with the minimum number of active devices in the signal path. Each amplifying device has its own “transfer characteristic” and when these are multiplied together in a complex design, the result is an overall transfer characteristic with high-order distortion products - the worst-sounding ones. The Artemis Labs LA-1 uses a single 5687 medium-mu, low resistance triode as the amplifying device for each channel. The 5687, originally designed by Tung-Sol for military and industrial uses, has excellent linearity, and in the mil-spec version, excellent unit-to-unit consistency. Its low plate resistance allows it to drive heavy loads without the use of a cathode follower stage.

The use of an inductor (choke) load instead of a conventional plate resistor offers several significant advantages to the LA-1 design. A good-quality audio choke is essentially a perfect current source, allowing the triode to operate into an infinite-resistance load, giving the lowest distortion. Unlike semiconductor constant-current devices, an inductor is an energy-storage device. This allows the plate

voltage to swing 100% above the B+ plate supply voltage, doubling the “head-room” and allowing a lower B+ supply voltage to be used, reducing power consumption. This large headroom permits output of over 40 volts rms before clipping.

The audio chokes used in the LA-1 are made by Lundahl, a Swedish firm that uses a proprietary core material that has low distortion. Two windings are used on a common “C-core”, which reduces pick-up of hum and noise.

Modest feedback stabilizes gain without hurting sonic quality

About 4dB of feedback is used across the single-triode amplifying stage. This stabilizes the gain and makes the frequency response less sensitive to loading. The inherent distortion of the 5687 with choke loading is already very low, so the high-order harmonics that can be generated by excessive feedback are minimal.

Can drive 8K ohm (aggregate) or higher loads

Despite the lack of a cathode-follower output stage, the LA-1 can drive loads as low as 8K while still meeting specifications. This is important when

driving certain solid-state amplifiers or pro audio equipment which can have input impedances as low as 10 or 15K ohms.

High-Quality Conductive-Plastic Balance pots

Since a stepped attenuator allows only discrete level steps, the balance controls are conductive plastic pots by Spectrol, which have a minimum impact on the sound. By using a separate pot for each channel, the default position (fully clockwise) permits full gain from the preamp.

Each channel individually voltage regulated

Each channel has its own MOSFET source-follower low-gain regulator. This insures there is no coupling between the two channels through the power supply. The source follower regulator gives good regulation without the “transistor sound” typical of high gain regulators using op-amps. Protection resistors and diodes help prevent burn-out of the MOSFETs.

True voltage regulation minimizes noises and changed operating conditions due to power line shifts. Since the impedance of the power supply, as seen by the amplifier, is low and flat, the bass response is even and solid.

Cool-Swap™ tube connections let tubes run cooler, provides built-in spare

Many dual triodes, such as the 12AX7 and 5687, have split heaters, allowing them to run from either 6.3V or 12.6V. This heater set-up allows only one of the two triodes to be heated. In the Cool-swap configuration used in the Artemis Labs LA-1, one tube is used for each channel, each with one half heated. The right channel uses triode #1 and the left channel uses triode #2. Since the main failure mode in modern tubes is cathode wear-out, the unused triode in each tube is essentially a spare. By swapping the two tubes, the unused spare is brought into use. Thus Cool-Swap essentially doubles tube life, and since only half the tube is heated, the tube runs cooler, an important factor in the normally hot-running 5687. A side benefit is reduced cross-talk between channels, since each channel has its own tube.

DC heater supply

A well-filtered DC heater supply helps keep hum low and allows the use of tubes that would otherwise have too much hum in AC-heated systems.

Delayed high-voltage with delayed muting relay

The high voltage plate supply is applied to the tubes after a delay of about 40 seconds. This gives the tubes ample chance to warm-up without the chance of “cathode stripping” (degradation of the cathode by bombardment by positive ions before it is hot enough to build-up a protective space charge around the cathode.) This helps extend tube life. A muting relay shorts the audio outputs until about 4 seconds after the high voltage is applied. This allows start-up transients to die away.

No troublesome integrated circuits

All time delay and regulation circuits use time-proven, simple discrete semiconductor devices.

Critical audio circuits point-to-point wired with military-style terminal boards

Conventional fiber-glass PC boards are used for the power supply and for the rear panel jacks and switching. All critical circuits in the audio path use point-to-point wiring on military-style terminal boards using silver-plated turrets. This technique minimizes the sonic effects of PC boards and allows easy component replacement.

High-speed rectifiers and electrostatically-shielded power transformer

Power supply noise is kept to a minimum by the use of a custom power transformer with electrostatic shielding between the primary and secondaries. High speed rectifiers are used for both the plate and heater supplies.

Available mains voltages (wired at factory): 100V, 110V, 120V, 220V, 230V, 240V, 50 or 60Hz

Virtually all the power systems of the world can be accommodated by the LA-1 transformer connections. These are set at the factory or can be re-wired by a qualified technician.

Artemis Labs products
are distributed by:

AYDN Vacuum Tube Audio
679 Easy Street, Unit E
Simi Valley, California 93065 USA

www.aydn.com
Tel: +1 818 216-7882
email: info@aydn.com